

Series 650

S-beam load cells for commercial weighing

capacities 250kg to 5000kg



stainless steel load sensor

tension/compression

2.0 mV/V rationalised output

range of accessories available

fully welded construction sealed to IP 68

excellent long term stability

five year warranty

3000 divisions OIML R60 class C

A range of Stainless steel "S" beam load cells for commercial weighing to OIML R60 3000 divisions. Welded construction ensures total environmental sealing coupled with excellent long term stability.



Thames Side - Maywood

...your specialist load cell partner

technical specification sheet

Series 650

Standard Load Ranges	250, 500, 1000, 2000, 5000	kg
Full Load Output	2.0 (+/- 10%)	mV/V
Excitation Recommended	10	V
Excitation Maximum	15	V
Safe Service Load	150	%
Ultimate Load	200	%
Combined Error	<±0.017	%
Repeatability	<±0.015	%
Output at Zero load	<±2.0	%
Input Resistance	400±20	ohms
Output Resistance	350±3	ohms
Operational Temperature Range	-20 to +70	°C
Compensated Temperature Range	-10 to +40	°C
Temperature Effect on Zero	<±0.01	%/5°K
Temperature Effect on Sensitivity	<±0.006	%/5°K
Creep 30 mins (at 20°C)	<±0.016	%
Environmental Protection	IP68	
Cable Length	5	m
Insulation	>5000	M ohms

All percentages are related to Full Rated Load

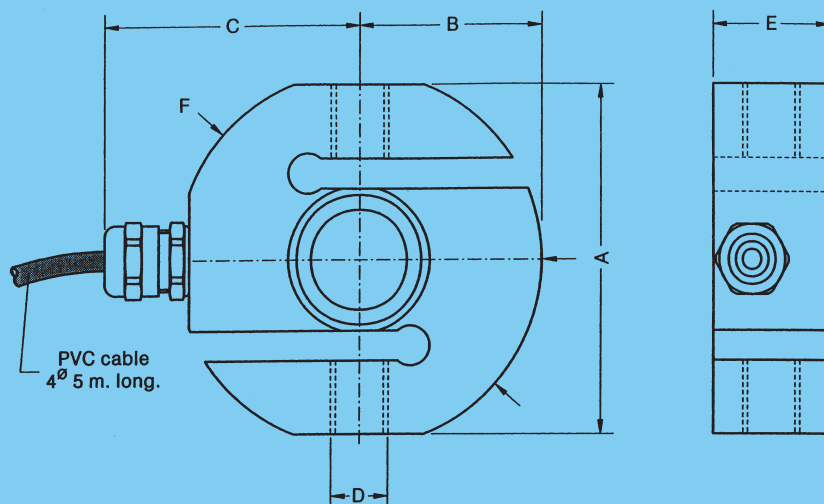

Nominal Load	A	B	C	D	E	Fø	Shipping Weight kg
250-500kg	70	37.5	50	M12x1.75	24.5	75	1
1-2te	95	50	60	M20x1.5	30	100	2
5te	120	62.5	72.5	M24x2	40	125	4

Dimensions in mm.

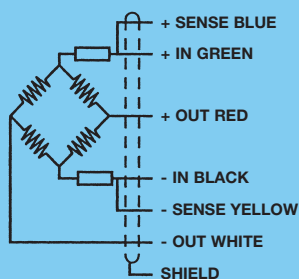

SENSES:
2 additional wires to maintain a constant voltage supply at the load cell when used with appropriate instrumentation. Use specially when long wires and wide temperature range.

Electrical Connections
Via 6 core, 4mm diameter screened pvc cable.

Construction
17-4PH stainless steel. Fully welded.

Screen not connected to load cell body.

Our policy is one of continuous product enhancement. We therefore reserve the right to incorporate technical modifications without prior notification.

Distributed by

Thames Side - Maywood

Thames Side-Maywood Limited

17 Stadium Way, Reading

Berkshire RG30 6BX, UK

Tel: +44(0)118 9458200

Fax: +44(0)118 9458225

E-mail: sales@thames-side.co.uk

Web: www.thames-side-maywood.com

